



Vanagon Skylights

The Original Skylight Guy

Skylight Installation Instructions

To remove your damaged skylight:

- Open skylight 1-2 turns with hand knob.
- Turn out set screw from hand wheel 1 and remove hand knob.
- Pry off plastic caps from hex nuts (arrows) and remove nuts.
- Remove cross-head screw 2.
- Remove roof vent bracket cover 3.
- Remove bracket 4 downwards from bolts.
- Remove skylight 5 with support bracket 4.
- Support arms 6 and hinges upward.

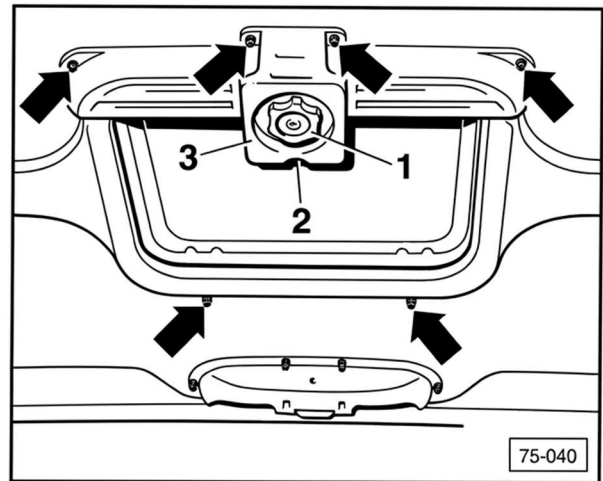

Installation Steps:

1. Clean off old hardware, nuts, and bolts. There may be caulking material, grit, grease that needs to be removed.
2. Examine hinges, straighten if necessary.
3. You may need to fix flex arms, especially the nylon washer at the end of the flex arm. Consider replacing it with a washer of the same size and gluing it on the flex arm with epoxy or crazy glue.
4. Check seal, possibly replace if damaged or cracked.
5. Carefully take the skylight from the plastic bubble wrap. You may want to handle it with a soft cloth so as not to mark it.

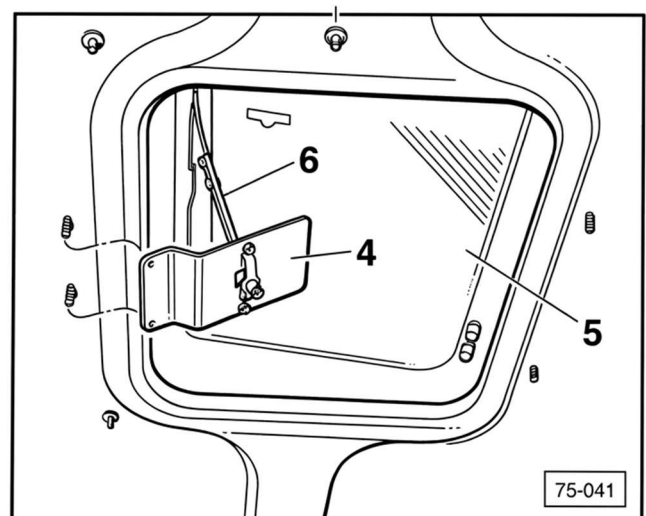

6. Install the skylight in reverse order of removal, noting the following: DO NOT FASTEN THE BOLTS TOO TIGHTLY. This may cause the skylight to crack!
-

When Installing Please Take These Precautions

- When re-using your hardware make sure it is cleaned off and straightened out.
- Check your seal, if it is brittle, has shown some shrinkage, or is no longer spongy; it may be a good time to replace it. A good way to check for leakage is to shut your skylight and spray it with the hose.
- When tightening the bolts, make sure they are only finger tight. Over tightening will cause your skylight to crack!
- DO NOT drive with your skylight open! This will cause little fissures in your skylight that will get larger and eventually crack.

Important

Your skylight comes with a one year warranty. Your warranty will only be honoured if installation and cleaning follows the manufacturer's recommendations. In order for your warranty to be valid, please follow these recommendations:

- **CLEANING:** Wash your skylight with a mild soap (dish washing liquid) and plenty of luke warm water. Blot dry with a soft cloth or chamois.
- **DUSTING:** Dust with a soft damp cloth or chamois. Dry or gritty cloths can scratch the surface.
- **POLISHING:** when necessary, wax your skylight occasionally with non-solvent auto paste wax, to protect it and maintain its surface gloss. Apply a thin even coat with a soft clean cloth, polish lightly with cotton flannel, then wipe with a soft damp cloth to help eliminate electrostatic charges.
- **TO REMOVE GREASE, OIL OR TAR:** Use a good grade of Hexane, Aliphatic Naphtha, or Kerosene. Obtain these products at a paint or hardware store, and follow manufacturers directions. Immediately wash away oily film with a mild soap and water solution.
- **DO NOT USE:** Window cleaning sprays, kitchen scouring compounds, or solvents such as acetone, gasoline, benzene, carbon tetrachloride, or lacquer thinner.
- **CAUTION:** Alcohol may cause grazing.